

BLACK WRINKLE FINISH  
ALL STEEL CONSTRUCTION  
PLASTIC LEVELOR GLIDES  
18 SHELVES  
FULLY WELDED  
SAMPLES ARE 12X24X3/8" THICK

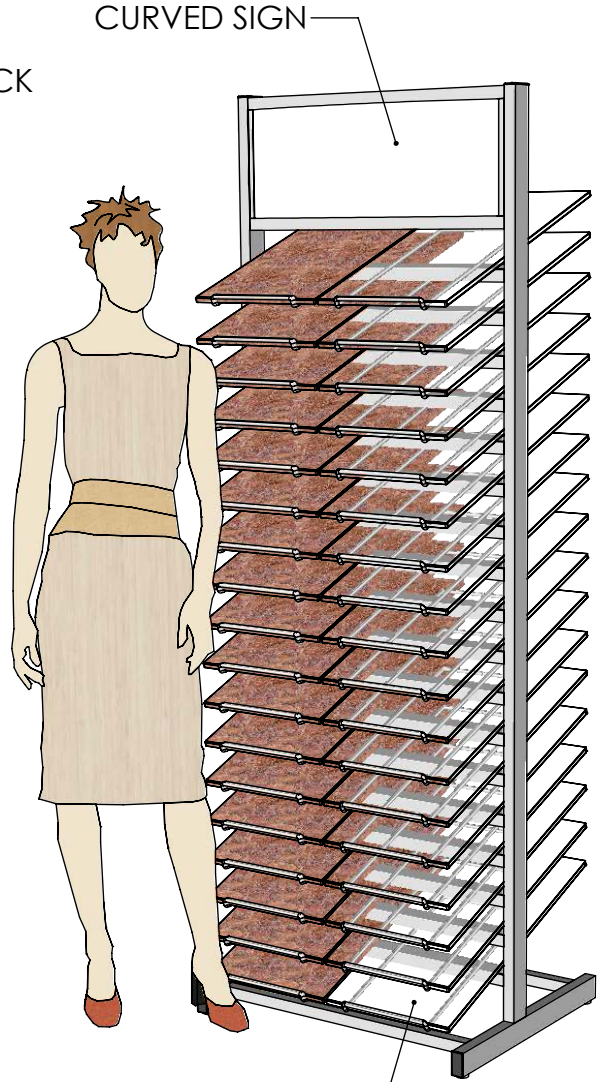

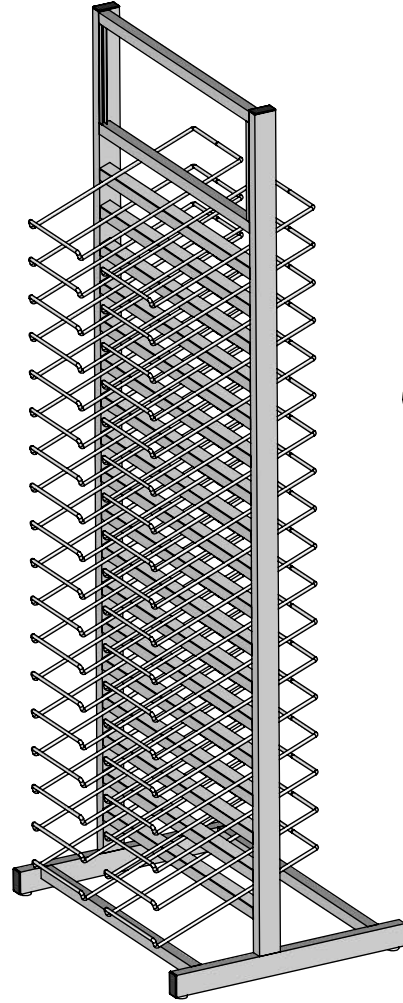
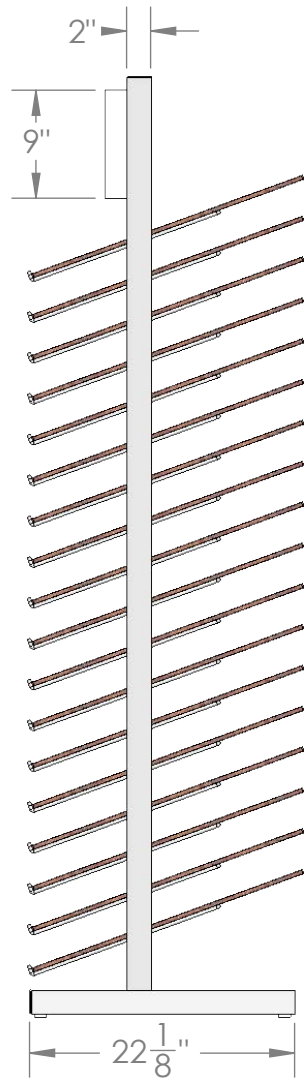
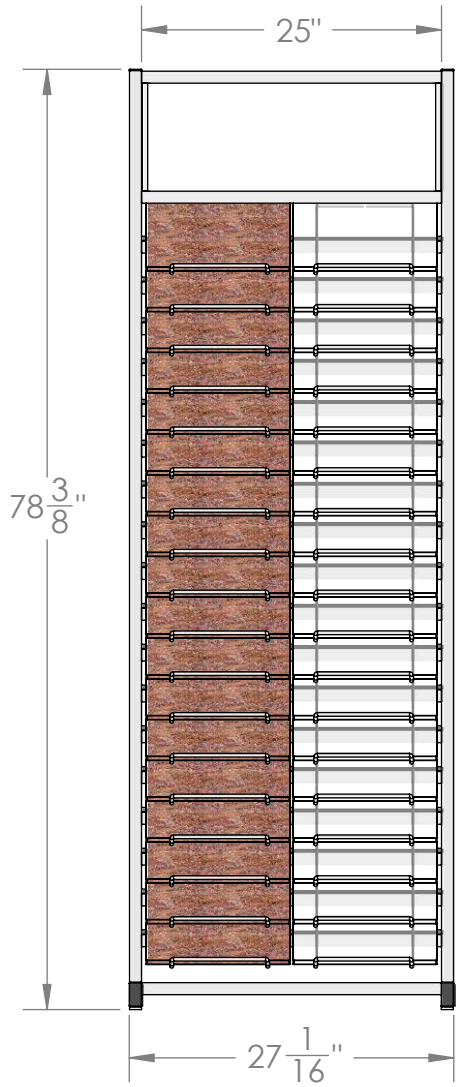
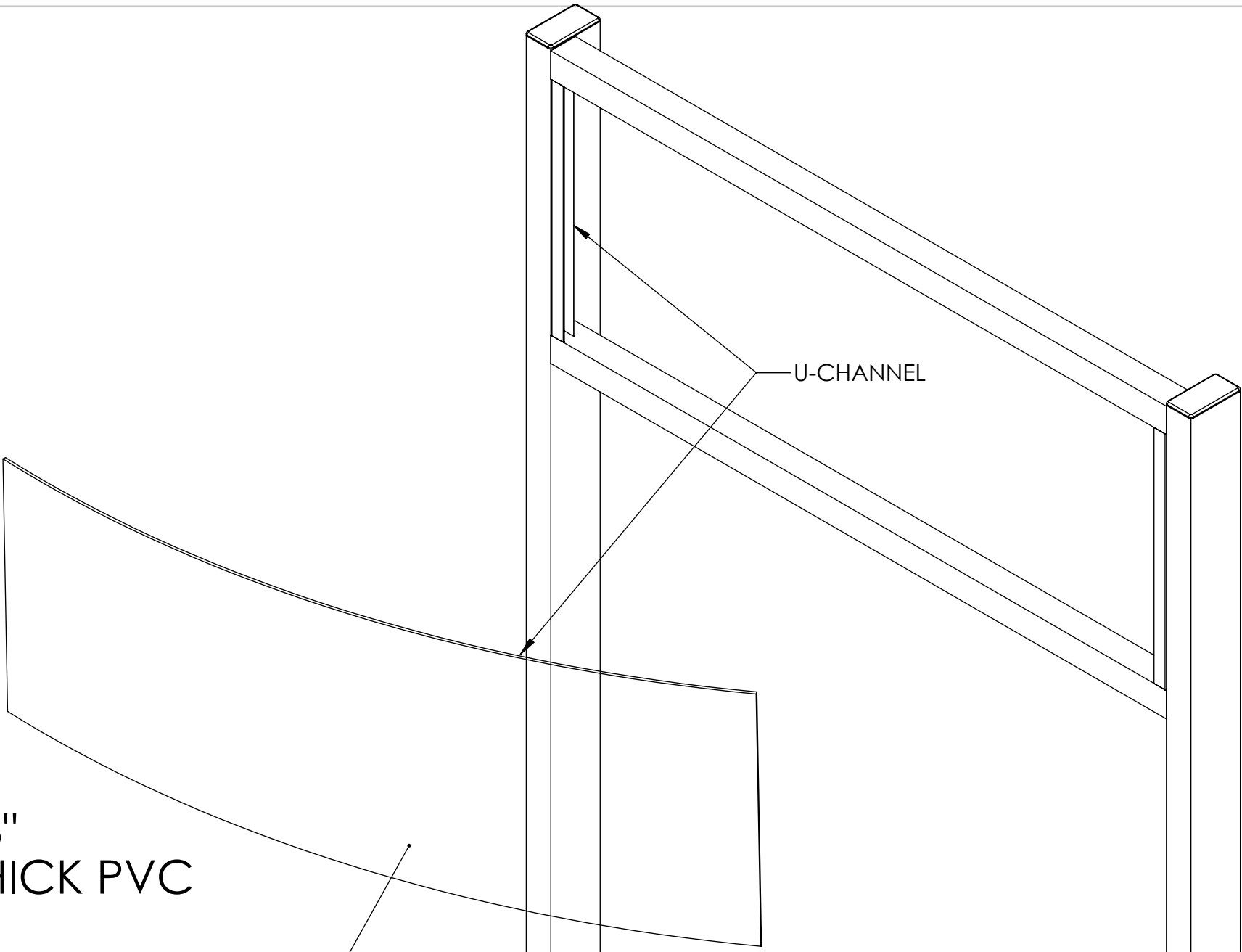

U-CHANNEL

9" X 26"  
1/8" THICK PVC

2-COLOR SCREEN LOGO