

Back

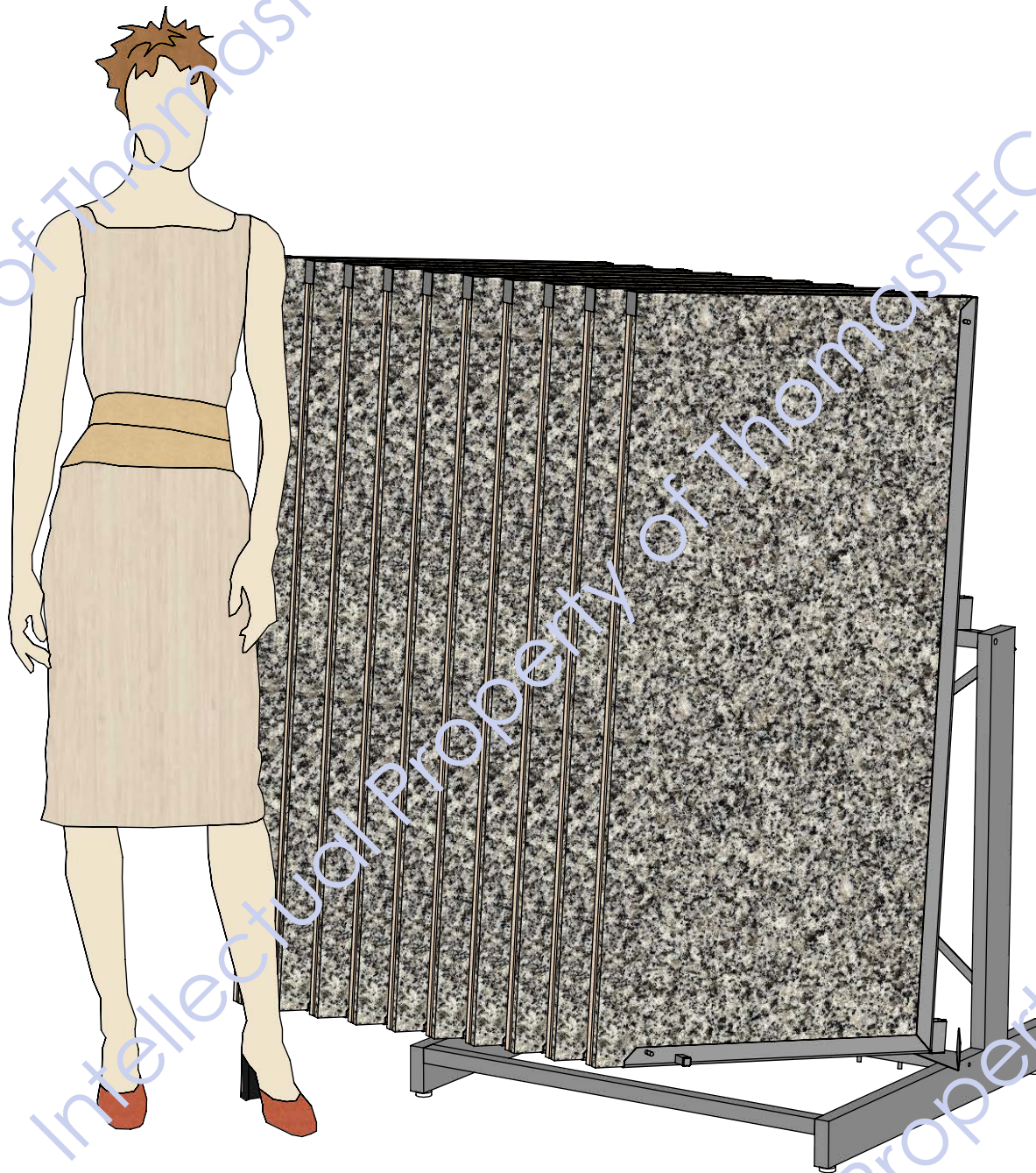

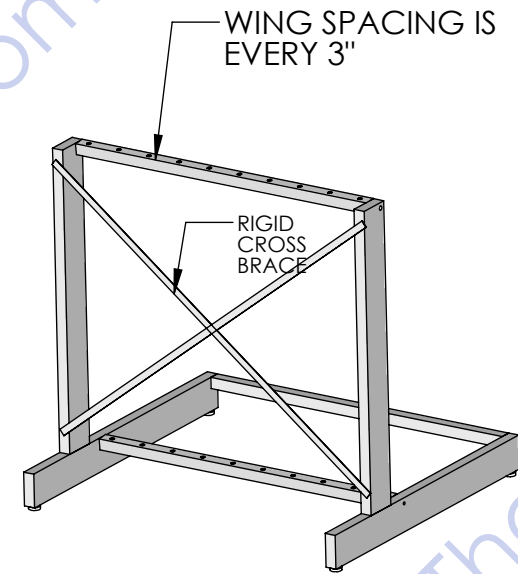

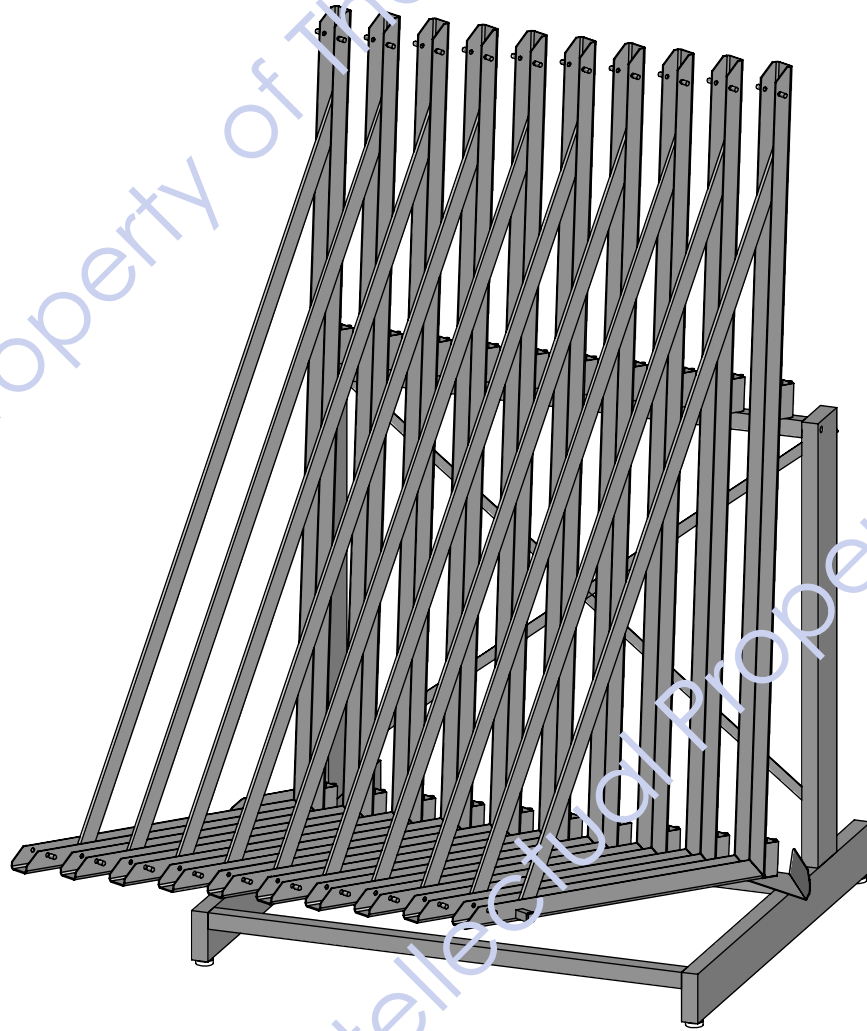
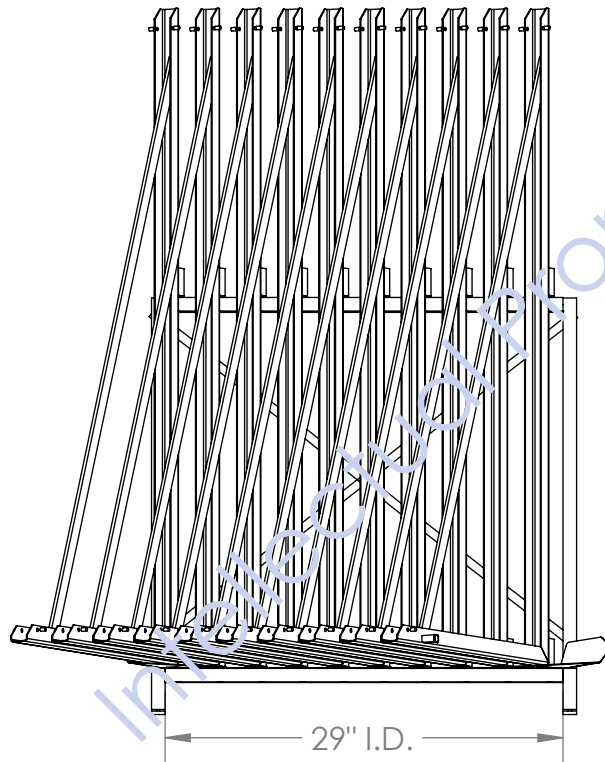
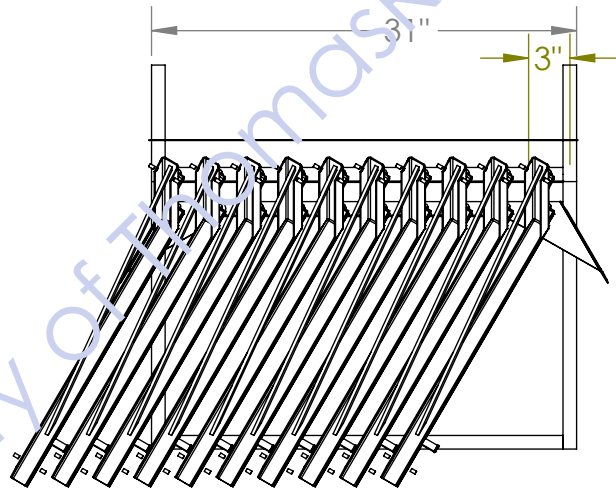

5 DEGREE
"LEAN BACK"
SHOWN HERE

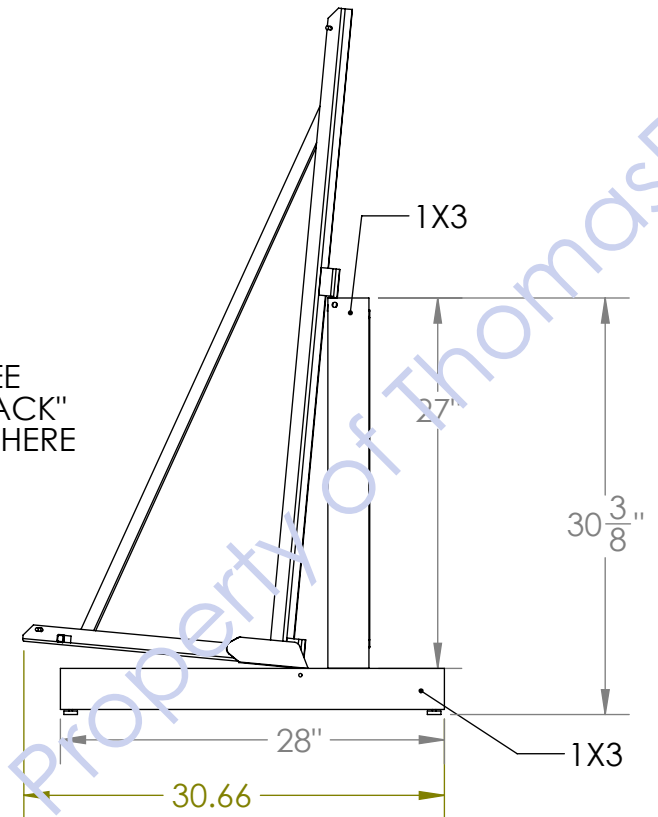

MUST HAVE THE (4) SET SCREWS AS SHOWN

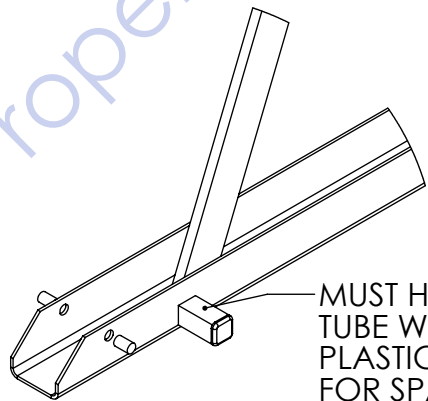

DETAIL A
SCALE 1 : 4

MUST HAVE
TUBE WITH
PLASTIC TIP
FOR SPACER
STOP

1/4X1
FLAT BAR

1/4" SET SCREWS (4)

WELD

48"

47.88

WELD

1/4" SET SCREWS (4)

14 GA CHANNELS

1/2" SQUARE TUBE WITH PLASTIC TIP

21 ⁷/₈"

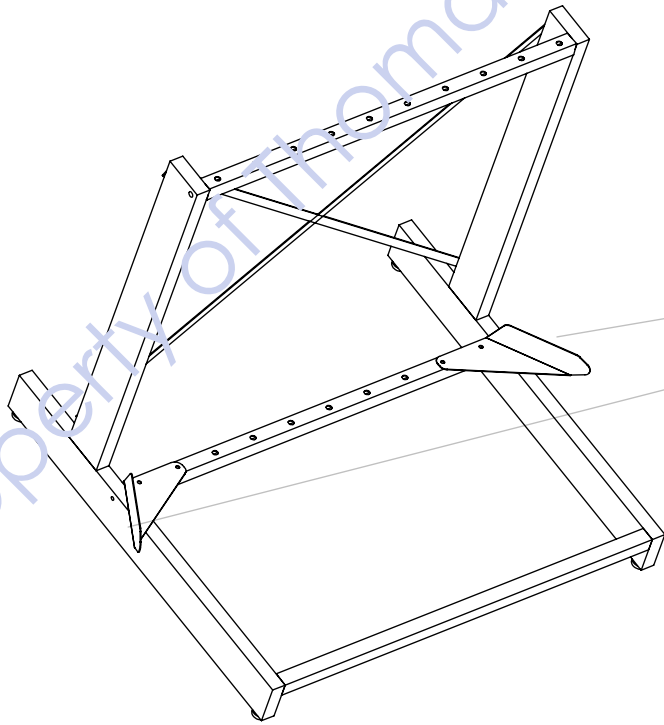

SHEET METAL "WING STOP"
(LEFT AND RIGHT)

